



Exposed Fastener Panels

Design/Installation Information

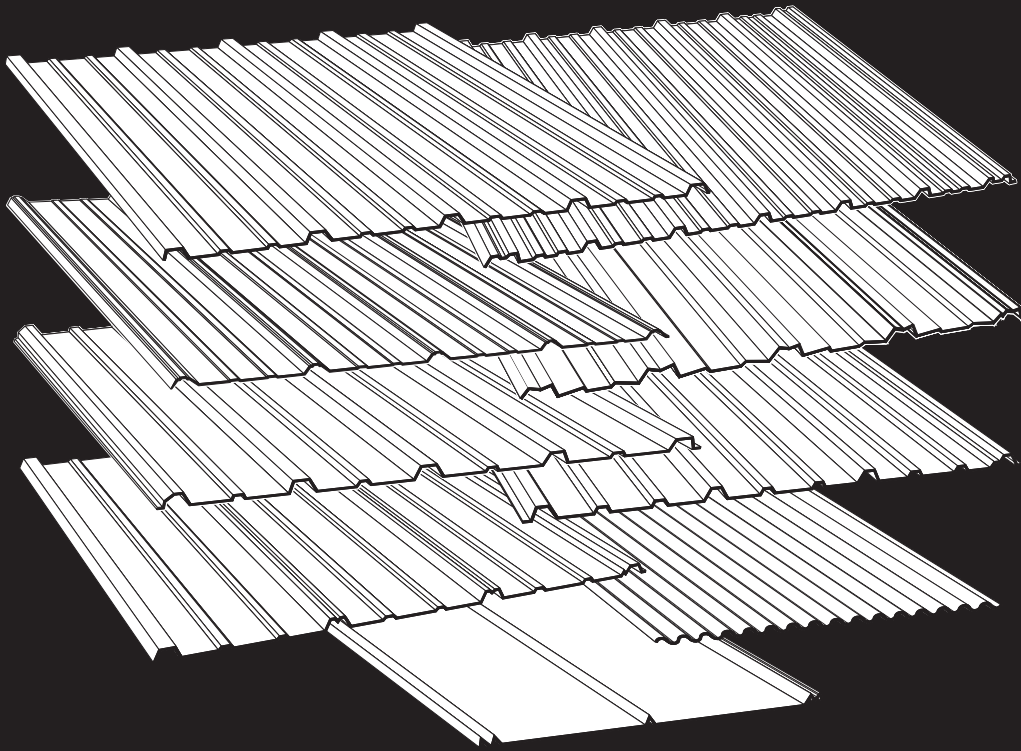

TABLE OF CONTENTS

A.	Imperial Rib®	TF-4
B.	Regal Rib®	TF-5
C.	Ameri-Drain®	TF-6
D.	Rugged Rib®	TF-7
E.	Monarch Rib®	TF-8
F.	Perma-Clad®	TF-9
G.	7/8" Wide Rib®	TF-10
H.	5V Crimp	TF-11
I.	Corrugated	TF-12
J.	Application Aids for Nails and Fasteners	TF-13
K.	Fastener Patterns for Screws	TF-14 - TF-16
L.	Typical Details	
	1. Endlap	TF-17
	2. Ridge	TF-18
	3. Valley	TF-19
	4. Hip	TF-20
	5. Rake	TF-21
	6. Eave	TF-22
	7. Gutter	TF-23

© Copyright American Building Components 2006
All Rights Reserved.
www.abcmetalroofing.com

CAUTION

Most of the Exposed Fastener load tables indicate the .015 nominal thickness panels can obtain a 20# live load on 4' - 0" or 5' - 0" centers. Please keep in mind these are uniform live loads and will not support a 200-pound man standing on one square foot. From an erectibility and industry standard point of view, it is recommended that you should not span the panels more than 3'-0".

EXPOSED FASTENER INFORMATION

IMPERIAL RIB® 36" Coverage

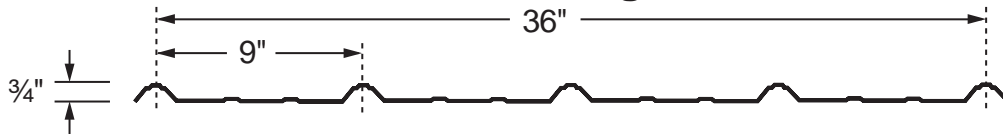

PANEL GAUGE	Fy (KSI)	WEIGHT (PSF)	SECTION PROPERTIES			SECTION PROPERTIES		
			NEGATIVE BENDING			POSITIVE BENDING		
			I _{xe} (IN.4/FT.)	S _{xe} (IN.3/FT.)	Maxo (KIP-IN.)	I _{xe} (IN.4/FT.)	S _{xe} (IN.3/FT.)	Maxo (KIP-IN.)
29	60*	0.63	0.0061	0.0173	0.6213	0.0102	0.0157	0.5651
26	60*	0.82	0.0083	0.0248	0.8919	0.0131	0.0205	0.7345

* Fy is 80 ksi reduced to 60 ksi in accordance with the 2001 edition of the *North American Specification For Design of Cold-Formed Steel Structural Members* - A2.3.2.

NOTES:

1. All calculations for the properties of Imperial Rib® panels are calculated in accordance with the 2001 edition of the *North American Specification For Design of Cold-Formed Steel Structural Members*.
2. I_{xe} is for deflection determination.
3. S_{xe} is for Bending.
4. Maxo is allowable bending moment.
5. All values are for the one foot of panel width.

29 Gauge (Fy = 60ksi)		ALLOWABLE UNIFORM LOADS IN POUNDS PER SQUARE FOOT						
SPAN TYPE	LOAD TYPE	SPAN IN FEET						
		2.0	2.5	3.0	3.5	4.0	4.5	5.0
SINGLE	Negative Wind Load	103.6	66.3	46.0	33.8	25.9	20.5	16.6
	Live Load/Deflection	94.2	57.1	33.0	20.8	13.9	9.8	7.1
2 SPAN	Negative Wind Load	94.2	60.3	41.9	30.8	23.5	18.6	15.1
	Live Load/Deflection	90.6	58.8	41.1	30.4	23.3	18.5	15.0
3 SPAN	Negative Wind Load	117.7	75.3	52.3	38.4	29.4	23.3	18.8
	Live Load/Deflection	111.5	72.7	51.0	37.7	26.3	18.5	13.5
4 SPAN	Negative Wind Load	109.9	70.4	48.9	35.9	27.5	21.7	17.6
	Live Load/Deflection	104.7	68.1	47.8	35.3	27.1	19.6	14.3

26 Gauge (Fy = 60ksi)		ALLOWABLE UNIFORM LOADS IN POUNDS PER SQUARE FOOT						
SPAN TYPE	LOAD TYPE	SPAN IN FEET						
		2.0	2.5	3.0	3.5	4.0	4.5	5.0
SINGLE	Negative Wind Load	148.7	95.1	66.1	48.5	37.2	29.4	23.8
	Live Load/Deflection	122.4	73.3	42.4	26.7	17.9	12.6	9.2
2 SPAN	Negative Wind Load	122.4	78.3	54.4	40.0	30.6	24.2	19.6
	Live Load/Deflection	117.8	76.4	53.5	39.5	30.3	24.0	19.5
3 SPAN	Negative Wind Load	153.0	97.9	68.0	50.0	38.3	30.2	24.5
	Live Load/Deflection	144.9	94.5	66.3	49.1	33.8	23.7	17.3
4 SPAN	Negative Wind Load	142.9	91.4	63.5	46.7	35.7	28.2	22.9
	Live Load/Deflection	136.1	88.6	62.1	45.9	35.3	25.2	18.3

NOTES:

1. Allowable loads are based on uniform span lengths and Fy = 60ksi.
2. LIVE LOAD is limited by bending, shear, combined shear & bending, or web crippling.
3. **NEGATIVE WIND LOAD does not contain a 33.333% increase and does not consider fastener pullout or pullover.**
4. Above loads consider a maximum deflection ratio of L/180.
5. The weight of the panel has not been deducted from the allowable loads.
6. The use of any accessories other than those provided by the manufacturer may damage panels, void all warranties and will void all engineering data.
7. This material is subject to change without notice.
8. See www.americanbuildingcomponents.com for most current information.

The Engineering data contained herein is for the expressed use of customers and design professionals. Along with this data, it is recommended that the design professional have a copy of the most current version of the *North American Specification for the Design of Cold-Formed Steel Structural Members* published by the *American Iron and Steel Institute* to facilitate design. This Specification contains the design criteria for cold-formed steel components. Along with the Specification, the designer should reference the most current building code applicable to the project jobsite in order to determine environmental loads. If further information or guidance regarding cold-formed design practices is desired, please contact the manufacturer.

EXPOSED FASTENER INFORMATION

REGAL RIB® 36" Coverage

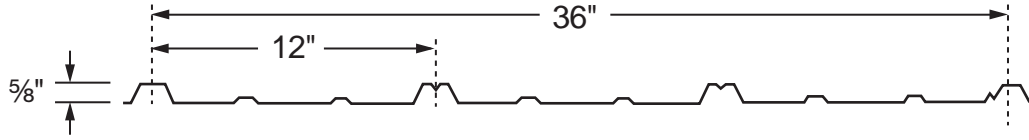

SECTION PROPERTIES								
PANEL GAUGE	Fy (KSI)	WEIGHT (PSF)	NEGATIVE BENDING			POSITIVE BENDING		
			lxe (IN.4/FT.)	Sxe (IN.3/FT.)	Maxo (KIP-IN.)	lxe (IN.4/FT.)	Sxe (IN.3/FT.)	Maxo (KIP-IN.)
29	60*	0.60	0.0028	0.0091	0.3273	0.0041	0.0095	0.3417
26	60*	0.78	0.0034	0.0126	0.4529	0.0053	0.0133	0.4777

*Fy is 80 ksi reduced to 60 ksi in accordance with the 2001 edition of the *North American Specification For Design of Cold-Formed Steel Structural Members* - A2.3.2.

NOTES:

- All calculations for the properties of Regal Rib® panels are calculated in accordance with the 2001 edition of the *North American Specification For Design of Cold-Formed Steel Structural Members*.
- lxe is for deflection determination.
- Sxe is for Bending.
- Maxo is allowable bending moment.
- All values are for the one foot of panel width.

29 Gauge (Fy = 60ksi)		ALLOWABLE UNIFORM LOADS IN POUNDS PER SQUARE FOOT						
SPAN TYPE	LOAD TYPE	SPAN IN FEET						
		2.0	2.5	3.0	3.5	4.0	4.5	5.0
SINGLE	Negative Wind Load	54.6	34.9	24.2	17.8	13.6	10.8	8.7
	Live Load/Deflection	44.8	22.9	13.3	8.4	5.6	3.9	2.9
2 SPAN	Negative Wind Load	57.0	36.4	25.3	18.6	14.2	11.2	9.1
	Live Load/Deflection	54.6	34.9	24.2	17.8	13.5	9.5	6.9
3 SPAN	Negative Wind Load	71.2	45.6	31.6	23.2	17.8	14.1	11.4
	Live Load/Deflection	67.9	43.3	25.0	15.8	10.6	7.4	5.4
4 SPAN	Negative Wind Load	66.5	42.5	29.5	21.7	16.6	13.1	10.6
	Live Load/Deflection	63.7	40.7	26.6	16.7	11.2	7.9	5.7

26 Gauge (Fy = 60ksi)		ALLOWABLE UNIFORM LOADS IN POUNDS PER SQUARE FOOT						
SPAN TYPE	LOAD TYPE	SPAN IN FEET						
		2.0	2.5	3.0	3.5	4.0	4.5	5.0
SINGLE	Negative Wind Load	75.5	48.3	33.5	24.6	18.9	14.9	12.1
	Live Load/Deflection	57.9	29.6	17.2	10.8	7.2	5.1	3.7
2 SPAN	Negative Wind Load	79.6	51.0	35.4	26.0	19.9	15.7	12.7
	Live Load/Deflection	75.5	48.3	33.5	24.6	17.4	12.2	8.9
3 SPAN	Negative Wind Load	99.5	63.7	44.2	32.5	24.9	19.7	15.9
	Live Load/Deflection	94.3	55.9	32.4	20.4	13.7	9.6	7.0
4 SPAN	Negative Wind Load	92.9	59.5	41.3	30.3	23.2	18.4	14.9
	Live Load/Deflection	88.1	56.4	34.4	21.6	14.5	10.2	7.4

NOTES:

- Allowable loads are based on uniform span lengths and Fy = 60ksi.
- LIVE LOAD is limited by bending, shear, combined shear & bending, or web crippling.
- NEGATIVE WIND LOAD does not contain a 33.333% increase and does not consider fastener pullout or pullover.**
- Above loads consider a maximum deflection ratio of L/180.
- The weight of the panel has not been deducted from the allowable loads.
- The use of any accessories other than those provided by the manufacturer may damage panels, void all warranties and will void all engineering data.
- This material is subject to change without notice.
- See www.americanbuildingcomponents.com for most current information.

The Engineering data contained herein is for the expressed use of customers and design professionals. Along with this data, it is recommended that the design professional have a copy of the most current version of the *North American Specification for the Design of Cold-Formed Steel Structural Members* published by the *American Iron and Steel Institute* to facilitate design. This Specification contains the design criteria for cold-formed steel components. Along with the Specification, the designer should reference the most current building code applicable to the project jobsite in order to determine environmental loads. If further information or guidance regarding cold-formed design practices is desired, please contact the manufacturer.

EXPOSED FASTENER INFORMATION

AMERI-DRAIN® 36" Coverage

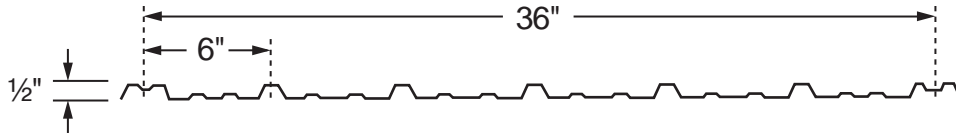

SECTION PROPERTIES								
PANEL GAUGE	Fy (KSI)	WEIGHT (PSF)	NEGATIVE BENDING			POSITIVE BENDING		
			lxe (IN.4/FT.)	Sxe (IN.3/FT.)	Maxo (KIP-IN.)	lxe (IN.4/FT.)	Sxe (IN.3/FT.)	Maxo (KIP-IN.)
29	60*	0.62	0.0028	0.0134	0.4814	0.0047	0.0126	0.4517
26	60*	0.80	0.0040	0.0192	0.6891	0.0062	0.0163	0.5848

* Fy is 80 ksi reduced to 60 ksi in accordance with the 2001 edition of the *North American Specification For Design of Cold-Formed Steel Structural Members* - A2.3.2.

NOTES:

1. All calculations for the properties of Ameri-Drain® panels are calculated in accordance with the 2001 edition of the *North American Specification For Design of Cold-Formed Steel Structural Members*.
2. lxe is for deflection determination.
3. Sxe is for Bending.
4. Maxo is allowable bending moment.
5. All values are for the one foot of panel width.

29 Gauge ALLOWABLE UNIFORM LOADS IN POUNDS PER SQUARE FOOT (Fy = 60ksi)								
SPAN TYPE	LOAD TYPE	SPAN IN FEET						
		2.0	2.5	3.0	3.5	4.0	4.5	5.0
SINGLE	Negative Wind Load	80.2	51.3	35.7	26.2	20.1	15.8	12.8
	Live Load/Deflection	51.4	26.3	15.2	9.6	6.4	4.5	3.3
2 SPAN	Negative Wind Load	75.3	48.2	33.5	24.6	18.8	14.9	12.0
	Live Load/Deflection	73.1	47.3	33.0	23.1	15.5	10.9	7.9
3 SPAN	Negative Wind Load	94.1	60.2	41.8	30.7	23.5	18.6	15.1
	Live Load/Deflection	90.2	49.6	28.7	18.1	12.1	8.5	6.2
4 SPAN	Negative Wind Load	87.9	56.2	39.1	28.7	22.0	17.4	14.1
	Live Load/Deflection	84.6	52.7	30.5	19.2	12.9	9.0	6.6

26 Gauge ALLOWABLE UNIFORM LOADS IN POUNDS PER SQUARE FOOT (Fy = 60ksi)								
SPAN TYPE	LOAD TYPE	SPAN IN FEET						
		2.0	2.5	3.0	3.5	4.0	4.5	5.0
SINGLE	Negative Wind Load	114.9	73.5	51.0	37.5	28.7	22.7	18.4
	Live Load/Deflection	67.7	34.7	20.1	12.6	8.5	5.9	4.3
2 SPAN	Negative Wind Load	97.5	62.4	43.3	31.8	24.4	19.3	15.6
	Live Load/Deflection	94.6	61.2	42.7	30.4	20.4	14.3	10.4
3 SPAN	Negative Wind Load	121.8	78.0	54.1	39.8	30.5	24.1	19.5
	Live Load/Deflection	116.8	64.4	37.9	23.9	16.0	11.2	8.2
4 SPAN	Negative Wind Load	113.8	72.8	50.6	37.1	28.4	22.5	18.2
	Live Load/Deflection	109.5	69.5	40.2	25.3	17.0	11.9	8.7

NOTES:

1. Allowable loads are based on uniform span lengths and Fy = 60ksi.
2. LIVE LOAD is limited by bending, shear, combined shear & bending, or web crippling.
3. **NEGATIVE WIND LOAD does not contain a 33.333% increase and does not consider fastener pullout or pullover.**
4. Above loads consider a maximum deflection ratio of L/180.
5. The weight of the panel has not been deducted from the allowable loads.
6. The use of any accessories other than those provided by the manufacturer may damage panels, void all warranties and will void all engineering data.
7. This material is subject to change without notice.
8. See www.americanbuildingcomponents.com for most current information.

The Engineering data contained herein is for the expressed use of customers and design professionals. Along with this data, it is recommended that the design professional have a copy of the most current version of the *North American Specification for the Design of Cold-Formed Steel Structural Members* published by the *American Iron and Steel Institute* to facilitate design. This Specification contains the design criteria for cold-formed steel components. Along with the Specification, the designer should reference the most current building code applicable to the project jobsite in order to determine environmental loads. If further information or guidance regarding cold-formed design practices is desired, please contact the manufacturer.

EXPOSED FASTENER INFORMATION

RUGGED RIB® 36" Coverage

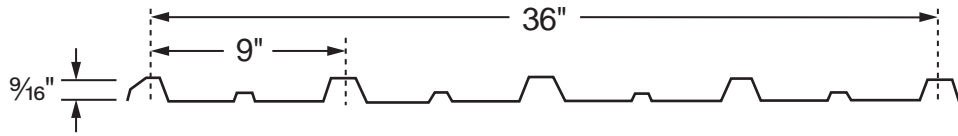

SECTION PROPERTIES								
PANEL GAUGE	Fy (KSI)	WEIGHT (PSF)	NEGATIVE BENDING			POSITIVE BENDING		
			l _{xe} (IN.4/FT.)	S _{xe} (IN.3/FT.)	Maxo (KIP-IN.)	l _{xe} (IN.4/FT.)	S _{xe} (IN.3/FT.)	Maxo (KIP-IN.)
29	60*	0.62	0.0044	0.0141	0.5052	0.0057	0.0124	0.4474
26	60*	0.81	0.0060	0.0197	0.7084	0.0082	0.0180	0.6484

*Fy is 80 ksi reduced to 60 ksi in accordance with the 2001 edition of the *North American Specification For Design of Cold-Formed Steel Structural Members* - A2.3.2.

NOTES:

- All calculations for the properties of Rugged Rib® panels are calculated in accordance with the 2001 edition of the *North American Specification For Design of Cold-Formed Steel Structural Members*.
- l_{xe} is for deflection determination.
- S_{xe} is for Bending.
- Maxo is allowable bending moment.
- All values are for the one foot of panel width.

29 Gauge (Fy = 60ksi)		ALLOWABLE UNIFORM LOADS IN POUNDS PER SQUARE FOOT						
SPAN TYPE	LOAD TYPE	SPAN IN FEET						
		2.0	2.5	3.0	3.5	4.0	4.5	5.0
SINGLE	Negative Wind Load	84.2	53.9	37.4	27.5	21.1	16.6	13.5
	Live Load/Deflection	62.3	31.9	18.5	11.6	7.8	5.5	4.0
2 SPAN	Negative Wind Load	74.6	47.7	33.1	24.3	18.6	14.7	11.9
	Live Load/Deflection	70.9	46.2	32.4	23.9	18.4	13.2	9.6
3 SPAN	Negative Wind Load	93.2	59.7	41.4	30.4	23.3	18.4	14.9
	Live Load/Deflection	86.9	57.0	34.8	21.9	14.7	10.3	7.5
4 SPAN	Negative Wind Load	87.0	55.7	38.7	28.4	21.8	17.2	13.9
	Live Load/Deflection	81.7	53.4	37.0	23.3	15.6	11.0	8.0

26 Gauge (Fy = 60ksi)		ALLOWABLE UNIFORM LOADS IN POUNDS PER SQUARE FOOT						
SPAN TYPE	LOAD TYPE	SPAN IN FEET						
		2.0	2.5	3.0	3.5	4.0	4.5	5.0
SINGLE	Negative Wind Load	118.1	75.6	52.5	38.6	29.5	23.3	18.9
	Live Load/Deflection	89.6	45.9	26.5	16.7	11.2	7.9	5.7
2 SPAN	Negative Wind Load	108.1	69.2	48.0	35.3	27.0	21.3	17.3
	Live Load/Deflection	101.7	66.5	46.7	34.6	26.6	18.9	13.8
3 SPAN	Negative Wind Load	135.1	86.5	60.0	44.1	33.8	26.7	21.6
	Live Load/Deflection	124.0	81.7	50.1	31.5	21.1	14.8	10.8
4 SPAN	Negative Wind Load	126.1	80.7	56.1	41.2	31.5	24.9	20.2
	Live Load/Deflection	116.8	76.7	53.2	33.5	22.4	15.8	11.5

NOTES:

- Allowable loads are based on uniform span lengths and Fy = 60ksi.
- LIVE LOAD is limited by bending, shear, combined shear & bending, or web crippling.
- NEGATIVE WIND LOAD does not contain a 33.333% increase and does not consider fastener pullout or pullover.**
- Above loads consider a maximum deflection ratio of L/180.
- The weight of the panel has not been deducted from the allowable loads.
- The use of any accessories other than those provided by the manufacturer may damage panels, void all warranties and will void all engineering data.
- This material is subject to change without notice.
- See www.americanbuildingcomponents.com for most current information.

The Engineering data contained herein is for the expressed use of customers and design professionals. Along with this data, it is recommended that the design professional have a copy of the most current version of the *North American Specification for the Design of Cold-Formed Steel Structural Members* published by the *American Iron and Steel Institute* to facilitate design. This Specification contains the design criteria for cold-formed steel components. Along with the Specification, the designer should reference the most current building code applicable to the project jobsite in order to determine environmental loads. If further information or guidance regarding cold-formed design practices is desired, please contact the manufacturer.

EXPOSED FASTENER INFORMATION

MONARCH RIB® 36" Coverage

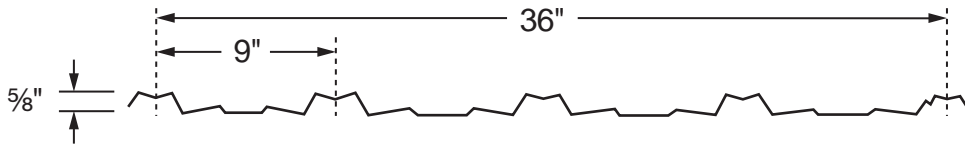

PANEL GAUGE	SECTION PROPERTIES							
	Fy (KSI)	WEIGHT (PSF)	NEGATIVE BENDING			POSITIVE BENDING		
			I _{xe} (IN.4/FT.)	S _{xe} (IN.3/FT.)	Maxo (KIP-IN.)	I _{xe} (IN.4/FT.)	S _{xe} (IN.3/FT.)	Maxo (KIP-IN.)
29	60*	0.61	0.0063	0.0215	0.7742	0.0075	0.0172	0.6192
26	60*	0.80	0.0088	0.0334	1.2002	0.0107	0.0246	0.8846

* Fy is 80 ksi reduced to 60 ksi in accordance with the 2001 edition of the *North American Specification For Design of Cold-Formed Steel Structural Members* - A2.3.2.

NOTES:

- All calculations for the properties of Monarch Rib® panels are calculated in accordance with the 2001 edition of the *North American Specification For Design of Cold-Formed Steel Structural Members*.
- I_{xe} is for deflection determination.
- S_{xe} is for Bending.
- Maxo is allowable bending moment.
- All values are for the one foot of panel width.

29 Gauge (Fy = 60ksi)		ALLOWABLE UNIFORM LOADS IN POUNDS PER SQUARE FOOT						
SPAN TYPE	LOAD TYPE	SPAN IN FEET						
		2.0	2.5	3.0	3.5	4.0	4.5	5.0
SINGLE	Negative Wind Load	129.0	82.6	57.3	42.1	32.3	25.5	20.6
	Live Load/Deflection	81.9	42.0	24.3	15.3	10.2	7.2	5.2
2 SPAN	Negative Wind Load	103.2	66.0	45.9	33.7	25.8	20.4	16.5
	Live Load/Deflection	98.5	64.1	44.9	33.2	24.7	17.3	12.6
3 SPAN	Negative Wind Load	129.0	82.6	57.3	42.1	32.3	25.5	20.6
	Live Load/Deflection	120.8	79.1	45.8	28.9	19.3	13.6	9.9
4 SPAN	Negative Wind Load	120.4	77.1	53.5	39.3	30.1	23.8	19.3
	Live Load/Deflection	113.6	74.2	48.6	30.6	20.5	14.4	10.5

26 Gauge (Fy = 60ksi)		ALLOWABLE UNIFORM LOADS IN POUNDS PER SQUARE FOOT						
SPAN TYPE	LOAD TYPE	SPAN IN FEET						
		2.0	2.5	3.0	3.5	4.0	4.5	5.0
SINGLE	Negative Wind Load	200.0	128.0	88.9	65.3	50.0	39.5	32.0
	Live Load/Deflection	116.9	59.9	34.6	21.8	14.6	10.3	7.5
2 SPAN	Negative Wind Load	147.4	94.4	65.5	48.1	36.9	29.1	23.6
	Live Load/Deflection	139.5	91.0	63.9	47.2	35.2	24.7	18.0
3 SPAN	Negative Wind Load	184.3	117.9	81.9	60.2	46.1	36.4	29.5
	Live Load/Deflection	170.5	112.1	65.4	41.2	27.6	19.4	14.1
4 SPAN	Negative Wind Load	172.1	110.1	76.5	56.2	43.0	34.0	27.5
	Live Load/Deflection	160.5	105.2	69.4	43.7	29.3	20.6	15.0

NOTES:

- Allowable loads are based on uniform span lengths and Fy = 60ksi.
- LIVE LOAD is limited by bending, shear, combined shear & bending, or web crippling.
- NEGATIVE WIND LOAD does not contain a 33.333% increase and does not consider fastener pullout or pullover.**
- Above loads consider a maximum deflection ratio of L/180.
- The weight of the panel has not been deducted from the allowable loads.
- The use of any accessories other than those provided by the manufacturer may damage panels, void all warranties and will void all engineering data.
- This material is subject to change without notice.
- See www.americanbuildingcomponents.com for most current information.

The Engineering data contained herein is for the expressed use of customers and design professionals. Along with this data, it is recommended that the design professional have a copy of the most current version of the *North American Specification for the Design of Cold-Formed Steel Structural Members* published by the *American Iron and Steel Institute* to facilitate design. This Specification contains the design criteria for cold-formed steel components. Along with the Specification, the designer should reference the most current building code applicable to the project jobsite in order to determine environmental loads. If further information or guidance regarding cold-formed design practices is desired, please contact the manufacturer.

EXPOSED FASTENER INFORMATION

PERMA-CLAD® 36" Coverage

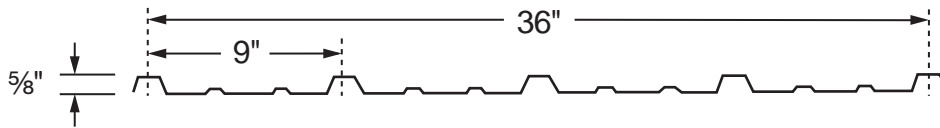

PANEL GAUGE	Fy (KSI)	WEIGHT (PSF)	NEGATIVE BENDING			POSITIVE BENDING		
			Ixe (IN.4/FT.)	Sxe (IN.3/FT.)	Maxo (KIP-IN.)	Ixe (IN.4/FT.)	Sxe (IN.3/FT.)	Maxo (KIP-IN.)
29	60*	0.61	0.0044	0.0153	0.5504	0.0066	0.0135	0.4863
26	60*	0.80	0.0063	0.0216	0.7764	0.0094	0.0190	0.6810

* Fy is 80 ksi reduced to 60 ksi in accordance with the 2001 edition of the *North American Specification For Design of Cold-Formed Steel Structural Members* - A2.3.2.

NOTES:

1. All calculations for the properties of Perma-Clad® panels are calculated in accordance with the 2001 edition of the *North American Specification For Design of Cold-Formed Steel Structural Members*.
2. Ixe is for deflection determination.
3. Sxe is for Bending.
4. Maxo is allowable bending moment.
5. All values are for the one foot of panel width.

29 Gauge (Fy = 60ksi)		ALLOWABLE UNIFORM LOADS IN POUNDS PER SQUARE FOOT						
SPAN TYPE	LOAD TYPE	SPAN IN FEET						
		2.0	2.5	3.0	3.5	4.0	4.5	5.0
SINGLE	Negative Wind Load	91.7	58.7	40.8	30.0	22.9	18.1	14.7
	Live Load/Deflection	72.1	36.9	21.4	13.5	9.0	6.3	4.6
2 SPAN	Negative Wind Load	81.1	51.9	36.0	26.5	20.3	16.0	13.0
	Live Load/Deflection	78.9	51.0	35.6	26.2	20.1	15.2	11.1
3 SPAN	Negative Wind Load	101.3	64.8	45.0	33.1	25.3	20.0	16.2
	Live Load/Deflection	97.5	63.2	40.3	25.4	17.0	11.9	8.7
4 SPAN	Negative Wind Load	94.6	60.5	42.0	30.9	23.6	18.7	15.1
	Live Load/Deflection	91.4	59.2	41.4	27.0	18.1	12.7	9.2

26 Gauge (Fy = 60ksi)		ALLOWABLE UNIFORM LOADS IN POUNDS PER SQUARE FOOT						
SPAN TYPE	LOAD TYPE	SPAN IN FEET						
		2.0	2.5	3.0	3.5	4.0	4.5	5.0
SINGLE	Negative Wind Load	129.4	82.8	57.5	42.3	32.4	25.6	20.7
	Live Load/Deflection	102.7	52.6	30.4	19.2	12.8	9.0	6.6
2 SPAN	Negative Wind Load	113.5	72.6	50.4	37.1	28.4	22.4	18.2
	Live Load/Deflection	110.0	71.2	49.7	36.7	28.1	21.7	15.8
3 SPAN	Negative Wind Load	141.9	90.8	63.1	46.3	35.5	28.0	22.7
	Live Load/Deflection	135.7	88.2	57.4	36.2	24.2	17.0	12.4
4 SPAN	Negative Wind Load	132.5	84.8	58.9	43.3	33.1	26.2	21.2
	Live Load/Deflection	127.3	82.6	57.8	38.4	25.7	18.1	13.2

NOTES:

1. Allowable loads are based on uniform span lengths and Fy = 60ksi.
2. LIVE LOAD is limited by bending, shear, combined shear & bending, or web crippling.
3. **NEGATIVE WIND LOAD does not contain a 33.333% increase and does not consider fastener pullout or pullover.**
4. Above loads consider a maximum deflection ratio of L/180.
5. The weight of the panel has not been deducted from the allowable loads.
6. The use of any accessories other than those provided by the manufacturer may damage panels, void all warranties and will void all engineering data.
7. This material is subject to change without notice.
8. See www.americanbuildingcomponents.com for most current information.

The Engineering data contained herein is for the expressed use of customers and design professionals. Along with this data, it is recommended that the design professional have a copy of the most current version of the *North American Specification for the Design of Cold-Formed Steel Structural Members* published by the *American Iron and Steel Institute* to facilitate design. This Specification contains the design criteria for cold-formed steel components. Along with the Specification, the designer should reference the most current building code applicable to the project jobsite in order to determine environmental loads. If further information or guidance regarding cold-formed design practices is desired, please contact the manufacturer.

EXPOSED FASTENER INFORMATION

7/8" WIDE RIB® 36" Coverage

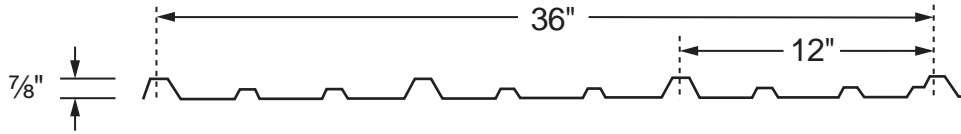

SECTION PROPERTIES								
PANEL GAUGE	Fy (KSI)	WEIGHT (PSF)	NEGATIVE BENDING			POSITIVE BENDING		
			l _{xe} (IN.4/FT.)	S _{xe} (IN.3/FT.)	Maxo (KIP-IN.)	l _{xe} (IN.4/FT.)	S _{xe} (IN.3/FT.)	Maxo (KIP-IN.)
29	60*	0.84	0.0069	0.0170	0.6108	0.0106	0.0143	0.5128
26	60*	1.06	0.0094	0.0242	0.8679	0.0153	0.0209	0.7503

* Fy is 80 ksi reduced to 60 ksi in accordance with the 2001 edition of the *North American Specification For Design of Cold-Formed Steel Structural Members* - A2.3.2.

NOTES:

- All calculations for the properties of 7/8" WIDE RIB® panels are calculated in accordance with the 2001 edition of the *North American Specification For Design of Cold-Formed Steel Structural Members*.
- l_{xe} is for deflection determination.
- S_{xe} is for Bending.
- Maxo is allowable bending moment.
- All values are for the one foot of panel width.

29 Gauge (Fy = 60ksi) ALLOWABLE UNIFORM LOADS IN POUNDS PER SQUARE FOOT								
SPAN TYPE	LOAD TYPE	SPAN IN FEET						
		2.0	2.5	3.0	3.5	4.0	4.5	5.0
SINGLE	Negative Wind Load	101.8	65.2	45.2	33.2	25.5	20.1	16.3
	Live Load/Deflection	85.5	54.7	34.3	21.6	14.5	10.2	7.4
2 SPAN	Negative Wind Load	85.5	54.7	38.0	27.9	21.4	16.9	13.7
	Live Load/Deflection	80.9	52.8	37.0	27.4	21.1	16.7	13.5
3 SPAN	Negative Wind Load	106.8	68.4	47.5	34.9	26.7	21.1	17.1
	Live Load/Deflection	98.9	65.0	45.8	34.0	26.2	19.2	14.0
4 SPAN	Negative Wind Load	99.8	63.8	44.3	32.6	24.9	19.7	16.0
	Live Load/Deflection	93.0	61.0	42.9	31.8	24.5	19.4	14.8

26 Gauge (Fy = 60ksi) ALLOWABLE UNIFORM LOADS IN POUNDS PER SQUARE FOOT								
SPAN TYPE	LOAD TYPE	SPAN IN FEET						
		2.0	2.5	3.0	3.5	4.0	4.5	5.0
SINGLE	Negative Wind Load	144.7	92.6	64.3	47.2	36.2	28.6	23.1
	Live Load/Deflection	125.1	80.0	49.5	31.2	20.9	14.7	10.7
2 SPAN	Negative Wind Load	125.1	80.0	55.6	40.8	31.3	24.7	20.0
	Live Load/Deflection	122.5	79.0	55.1	40.5	31.1	24.6	19.9
3 SPAN	Negative Wind Load	156.3	100.0	69.5	51.0	39.1	30.9	25.0
	Live Load/Deflection	151.7	98.1	68.5	50.5	38.8	27.7	20.2
4 SPAN	Negative Wind Load	146.0	93.4	64.9	47.7	36.5	28.8	23.4
	Live Load/Deflection	142.1	91.8	64.1	47.2	36.2	28.7	21.4

NOTES:

- Allowable loads are based on uniform span lengths and Fy = 60ksi.
- LIVE LOAD is limited by bending, shear, combined shear & bending, or web crippling.
- NEGATIVE WIND LOAD does not contain a 33.333% increase and does not consider fastener pullout or pullover.**
- Above loads consider a maximum deflection ratio of L/180.
- The weight of the panel has not been deducted from the allowable loads.
- The use of any accessories other than those provided by the manufacturer may damage panels, void all warranties and will void all engineering data.
- This material is subject to change without notice.
- See www.americanbuildingcomponents.com for most current information.

The Engineering data contained herein is for the expressed use of customers and design professionals. Along with this data, it is recommended that the design professional have a copy of the most current version of the *North American Specification for the Design of Cold-Formed Steel Structural Members* published by the *American Iron and Steel Institute* to facilitate design. This Specification contains the design criteria for cold-formed steel components. Along with the Specification, the designer should reference the most current building code applicable to the project jobsite in order to determine environmental loads. If further information or guidance regarding cold-formed design practices is desired, please contact the manufacturer.

EXPOSED FASTENER INFORMATION

5V CRIMP 24" Coverage

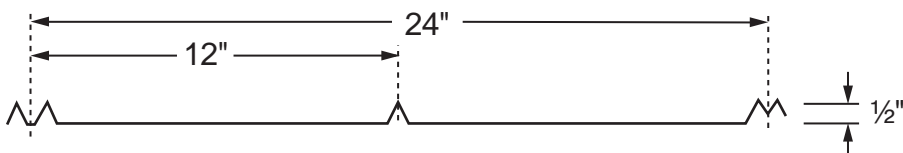

SECTION PROPERTIES

PANEL GAUGE	F _y (KSI)	WEIGHT (PSF)	NEGATIVE BENDING			POSITIVE BENDING		
			I _{xe} (IN.4/FT.)	S _{xe} (IN.3/FT.)	Maxo (KIP-IN.)	I _{xe} (IN.4/FT.)	S _{xe} (IN.3/FT.)	Maxo (KIP-IN.)
29	60*	0.75	0.0014	0.0074	0.2662	0.0028	0.0061	0.2204
26	60*	0.95	0.0018	0.0112	0.4018	0.0032	0.0079	0.2826

*F_y is 80 ksi reduced to 60 ksi in accordance with the 2001 edition of the *North American Specification For Design of Cold-Formed Steel Structural Members* - A2.3.2.

NOTES:

- All calculations for the properties of 5V Crimp panels are calculated in accordance with the 2001 edition of the *North American Specification For Design of Cold-Formed Steel Structural Members*.
- I_{xe} is for deflection determination.
- S_{xe} is for Bending.
- Maxo is allowable bending moment.
- All values are for the one foot of panel width.

29 Gauge (F _y = 60ksi)		ALLOWABLE UNIFORM LOADS IN POUNDS PER SQUARE FOOT						
SPAN TYPE	LOAD TYPE	SPAN IN FEET						
		1.0	1.5	2.0	2.5	3.0	3.5	4.0
SINGLE	Negative Wind Load	177.5	78.9	44.4	28.4	19.7	14.5	11.1
	Live Load/Deflection	146.9	65.3	30.2	15.4	8.9	5.6	3.8
2 SPAN	Negative Wind Load	146.9	65.3	36.7	23.5	16.3	12.0	9.2
	Live Load/Deflection	142.1	64.3	36.4	23.4	16.3	12.0	9.1
3 SPAN	Negative Wind Load	183.7	81.6	45.9	29.4	20.4	15.0	11.5
	Live Load/Deflection	172.5	79.9	45.4	29.1	16.9	10.6	7.1
4 SPAN	Negative Wind Load	171.5	76.2	42.9	27.4	19.1	14.0	10.7
	Live Load/Deflection	164.4	74.8	42.4	27.2	17.9	11.3	7.6

26 Gauge (F _y = 60ksi)		ALLOWABLE UNIFORM LOADS IN POUNDS PER SQUARE FOOT						
SPAN TYPE	LOAD TYPE	SPAN IN FEET						
		1.0	1.5	2.0	2.5	3.0	3.5	4.0
SINGLE	Negative Wind Load	267.9	119.1	67.0	42.9	29.8	21.9	16.7
	Live Load/Deflection	188.4	83.4	35.2	18.0	10.4	6.6	4.4
2 SPAN	Negative Wind Load	188.4	83.7	47.1	30.1	20.9	15.4	11.8
	Live Load/Deflection	182.4	82.5	46.7	30.0	20.9	15.3	10.6
3 SPAN	Negative Wind Load	235.5	104.7	58.9	37.7	26.2	19.2	14.7
	Live Load/Deflection	224.9	102.5	58.2	34.0	19.7	12.4	8.3
4 SPAN	Negative Wind Load	219.9	97.7	55.0	35.2	24.4	18.0	13.7
	Live Load/Deflection	211.0	95.9	54.4	34.9	20.9	13.2	8.8

NOTES:

- Allowable loads are based on uniform span lengths and F_y = 60ksi.
- LIVE LOAD is limited by bending, shear, combined shear & bending, or web crippling.
- NEGATIVE WIND LOAD does not contain a 33.333% increase and does not consider fastener pullout or pullover.**
- Above loads consider a maximum deflection ratio of L/180.
- The weight of the panel has not been deducted from the allowable loads.
- The use of any accessories other than those provided by the manufacturer may damage panels, void all warranties and will void all engineering data.
- This material is subject to change without notice.
- See www.americanbuildingcomponents.com for most current information.

The Engineering data contained herein is for the expressed use of customers and design professionals. Along with this data, it is recommended that the design professional have a copy of the most current version of the *North American Specification for the Design of Cold-Formed Steel Structural Members* published by the *American Iron and Steel Institute* to facilitate design. This Specification contains the design criteria for cold-formed steel components. Along with the Specification, the designer should reference the most current building code applicable to the project jobsite in order to determine environmental loads. If further information or guidance regarding cold-formed design practices is desired, please contact the manufacturer.

EXPOSED FASTENER INFORMATION

CORRUGATED 24" Coverage

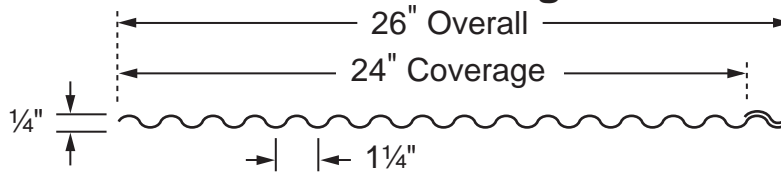

PANEL GAUGE	SECTION PROPERTIES							
	Fy (KSI)	WEIGHT (PSF)	NEGATIVE BENDING			POSITIVE BENDING		
			lxe (IN.4/FT.)	Sxe (IN.3/FT.)	Maxo (KIP-IN.)	lxe (IN.4/FT.)	Sxe (IN.3/FT.)	Maxo (KIP-IN.)
29	60*	0.61	0.0014	0.0093	0.3356	0.0014	0.0093	0.3356
26	60*	0.79	0.0014	0.0119	0.4271	0.0014	0.0119	0.4271

* Fy is 80 ksi reduced to 60 ksi in accordance with the 2001 edition of the *North American Specification For Design of Cold-Formed Steel Structural Members* - A2.3.2.

NOTES:

- All calculations for the properties of Corrugated panels are calculated in accordance with the 2001 edition of the *North American Specification For Design of Cold-Formed Steel Structural Members*.
- lxe is for deflection determination.
- Sxe is for Bending.
- Maxo is allowable bending moment.
- All values are for the one foot of panel width.

29 Gauge (Fy = 60ksi)		ALLOWABLE UNIFORM LOADS IN POUNDS PER SQUARE FOOT							
SPAN TYPE	LOAD TYPE	SPAN IN FEET							
		2.0	2.5	3.0	3.5	4.0	4.5	5.0	
SINGLE	Negative Wind Load	55.9	35.8	24.9	18.3	14.0	11.0	8.9	
	Live Load/Deflection	15.3	7.8	4.5	2.9	1.9	1.3	1.0	
2 SPAN	Negative Wind Load	55.9	35.8	24.9	18.3	14.0	11.0	8.9	
	Live Load/Deflection	36.8	18.9	10.9	6.9	4.6	3.2	2.4	
3 SPAN	Negative Wind Load	69.9	44.7	31.1	22.8	17.5	13.8	11.2	
	Live Load/Deflection	28.9	14.8	8.6	5.4	3.6	2.5	1.8	
4 SPAN	Negative Wind Load	65.3	41.8	29.0	21.3	16.3	12.9	10.4	
	Live Load/Deflection	30.6	15.7	9.1	5.7	3.8	2.7	2.0	

26 Gauge (Fy = 60ksi)		ALLOWABLE UNIFORM LOADS IN POUNDS PER SQUARE FOOT							
SPAN TYPE	LOAD TYPE	SPAN IN FEET							
		2.0	2.5	3.0	3.5	4.0	4.5	5.0	
SINGLE	Negative Wind Load	71.2	45.6	31.6	23.2	17.8	14.1	11.4	
	Live Load/Deflection	15.3	7.8	4.5	2.9	1.9	1.3	1.0	
2 SPAN	Negative Wind Load	71.2	45.6	31.6	23.2	17.8	14.1	11.4	
	Live Load/Deflection	36.8	18.9	10.9	6.9	4.6	3.2	2.4	
3 SPAN	Negative Wind Load	89.0	56.9	39.5	29.1	22.2	17.6	14.2	
	Live Load/Deflection	28.9	14.8	8.6	5.4	3.6	2.5	1.8	
4 SPAN	Negative Wind Load	83.1	53.2	36.9	27.1	20.8	16.4	13.3	
	Live Load/Deflection	30.6	15.7	9.1	5.7	3.8	2.7	2.0	

NOTES:

- Allowable loads are based on uniform span lengths and Fy = 60ksi.
- LIVE LOAD is limited by bending, shear, combined shear & bending, or web crippling.
- NEGATIVE WIND LOAD does not contain a 33.333% increase and does not consider fastener pullout or pullover.**
- Above loads consider a maximum deflection ratio of L/180.
- The weight of the panel has not been deducted from the allowable loads.
- The use of any accessories other than those provided by the manufacturer may damage panels, void all warranties and will void all engineering data.
- This material is subject to change without notice.
- See www.americanbuildingcomponents.com for most current information.

The Engineering data contained herein is for the expressed use of customers and design professionals. Along with this data, it is recommended that the design professional have a copy of the most current version of the *North American Specification for the Design of Cold-Formed Steel Structural Members* published by the *American Iron and Steel Institute* to facilitate design. This Specification contains the design criteria for cold-formed steel components. Along with the Specification, the designer should reference the most current building code applicable to the project jobsite in order to determine environmental loads. If further information or guidance regarding cold-formed design practices is desired, please contact the manufacturer.

EXPOSED FASTENER INFORMATION

APPLICATION AID FOR NAILS

The following is intended as a general guideline and is representative of typical nail placement used in the post frame industry. Consult a qualified engineer or architect for the specific requirements needed to meet local design codes, weather conditions or other related factors. NOTE: Panels are not symmetrical side to side. Always follow correct Side Lap Procedure.

ROOFING

1. The critical point in laying a roof is correct positioning of the first sheet on the side away from prevailing winds. Check both ends of this sheet to be sure it's square to insure true fit of roofing sheets.
2. Once the first sheet is accurately positioned, nail the top and bottom edge to secure it in place. (See illustrations at right for your particular roofing or siding.)
3. For both roofing and siding, always start the first course on the lower side or edge of the building away from the prevailing winds, working from eave to ridge.
4. Nails should be galvanized, ring shank, with a rubber washer (See chart below). These are vital for a waterproof roof. For roofing, nails should be at least 2" long. If insulation is used, increase nail length accordingly.
5. Avoid over-driving nails. Washers should be flush with steel. Overdriving distorts sheets and creates the possibility of leaks. (See illustration OVERDRIVING NAILS far right.)

IMPERIAL RIB®

Nail the sheet securely in position nailing through the top of every major rib. Roofing nails should be placed in the crown (high point) of the ribs only.

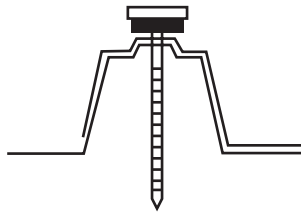

RUGGED RIB®

Nail the sheet securely in position nailing through the top of every major rib. DO NOT FASTEN IN THE CENTER OF THE RIB, rather nail toward the side. THIS IS VERY IMPORTANT!

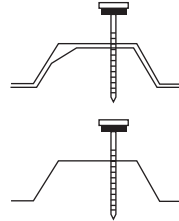

AMERI-DRAIN®

Nail the sheet securely in position nailing through the top of every major rib. Roofing nails should be placed in the crown (high point).

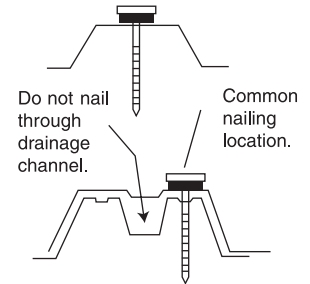

REGAL RIB®

Nail the sheet securely in position nailing through the top of every major rib. DO NOT NAIL IN THE CENTER OF V, NOR IN CENTER OF DRAIN RIB AT THE SIDE LAP.

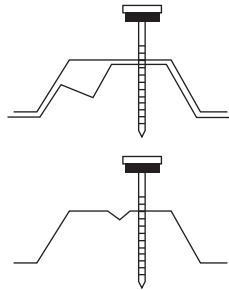

MONARCH RIB®

Nail the sheet securely in position nailing through the top of every major rib. IMPORTANT; nail perpendicular to slanted surface as indicated.

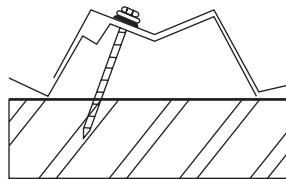

DRIVING NAILS

UNDER-DRIVEN

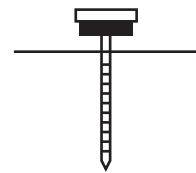

CORRECT

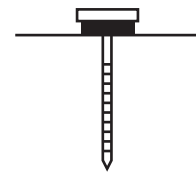

OVER-DRIVEN

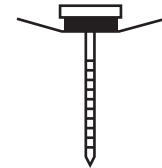

10 Gauge, 3/8" Flat Checkered Head, Ring Shank, Rubber Washer Roofing

NOTE: 80 per square (average quantity required) you may require more or less depending on wind load, purlin spacing, etc. Consult an engineer for specific requirements.

LENGTH

NAILS PER POUND

1 1/2"

126

2"

100

2 1/2"

82

3"

70

SIDING

Generally a 1 1/2" long nail is adequate for wall panels. However, insulation thickness, wind loads or other engineering factors could require longer nails. Consult a qualified engineer for your specific application. Nails should be placed in the flat of the sheet, next to the major rib, except at side laps. Side laps should be nailed through the crown, refer to the roofing segment above.

NOTE: Extended life fasteners are available. Call for pricing.

NOTE: In nailing any kind of roofing or siding, nail the outside ribs first, then the center ribs. This will eliminate spreading or creeping of the sheet. This is especially important when sheets are end-lapped to prevent a mismatch. When using a single long sheet from ridge to eave, the spreading may distort the appearance of the finished building.

EXPOSED FASTENER INFORMATION

FASTENER PATTERN FOR SCREWS

RUGGED RIB®

Panel Coverage: 36"
Major Rib Spacing: 9"

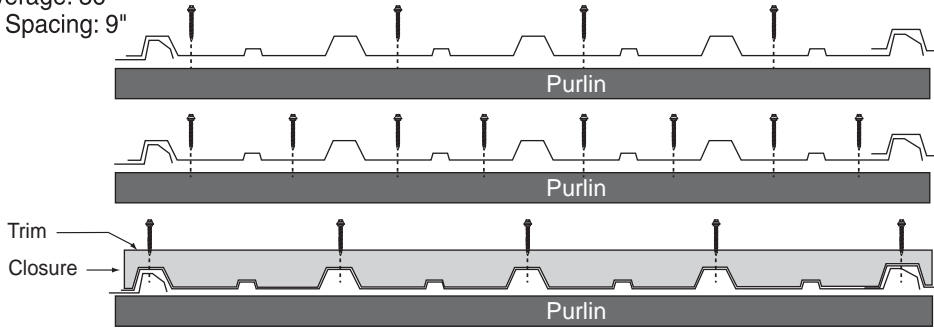

Typical fastener placement at intermediate purlins.

Typical fastener placement at endlaps and eave strut.

Typical fastener placement at ridge.

REGAL RIB®

Panel Coverage: 36"
Major Rib Spacing: 12"

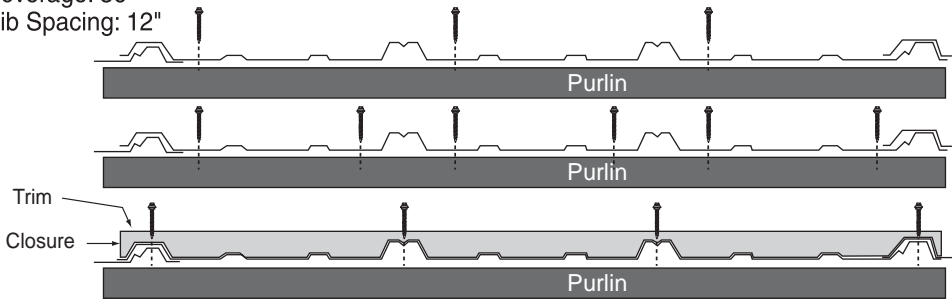

Typical fastener placement at intermediate purlins.

Typical fastener placement at endlaps and eave strut.

Typical fastener placement at ridge.

AMERI-DRAIN®

Panel Coverage: 36"
Major Rib Spacing: 6"

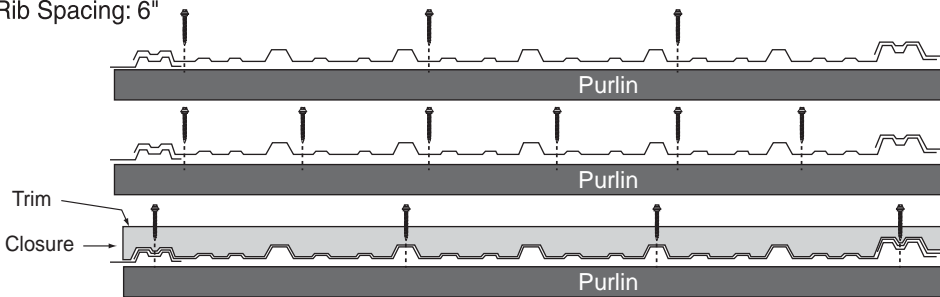

Typical fastener placement at intermediate purlins.

Typical fastener placement at endlaps and eave strut.

Typical fastener placement at ridge.

IMPERIAL RIB®

Panel Coverage: 36"
Major Rib Spacing: 9"

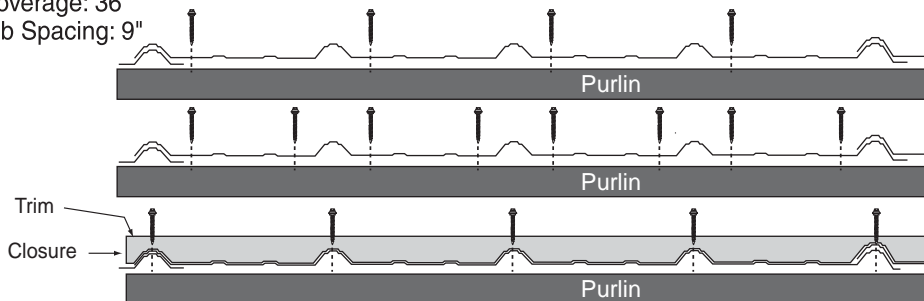

Typical fastener placement at intermediate purlins.

Typical fastener placement at endlaps and eave strut.

Typical fastener placement at ridge.

Note: Using a depth setting nosepiece is recommended for proper installation.

EXPOSED FASTENER INFORMATION

FASTENER PATTERN FOR SCREWS

PERMA-CLAD®

Panel Coverage: 36"
Major Rib Spacing: 9"

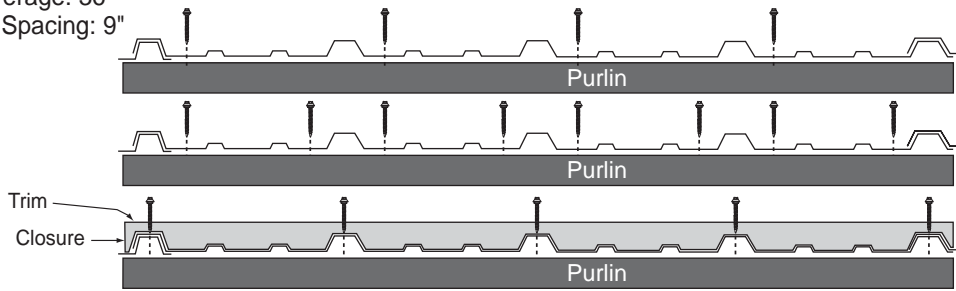

Typical fastener placement at intermediate purlins.

Typical fastener placement at endlaps and eave strut.

Typical fastener placement at ridge.

7/8" WIDE RIB®

Panel Coverage: 36"
Major Rib Spacing: 12"

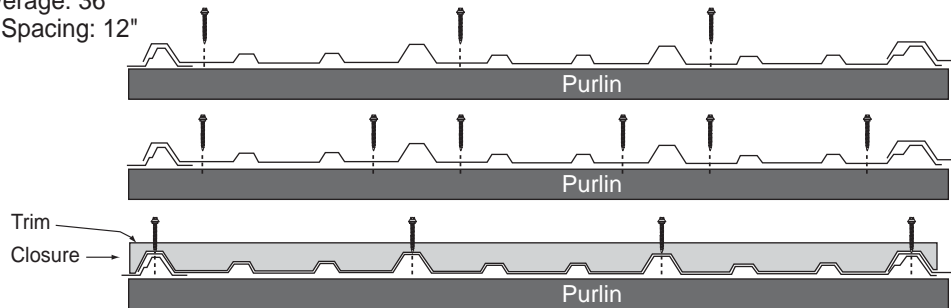

Typical fastener placement at intermediate purlins.

Typical fastener placement at endlaps and eave strut.

Typical fastener placement at ridge.

MONARCH RIB®

Panel Coverage: 36"
Major Rib Spacing: 9"

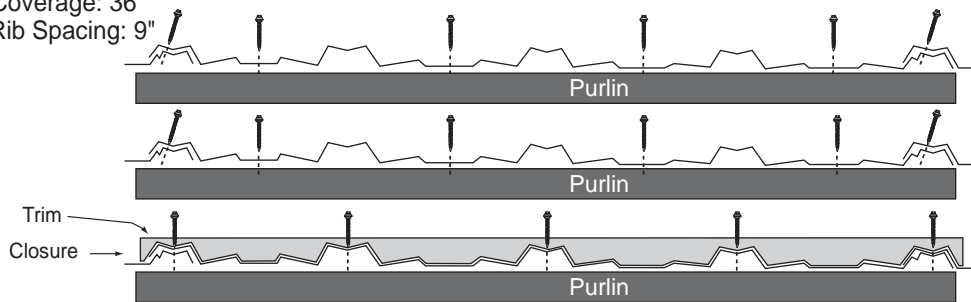

Typical fastener placement at intermediate purlins.

Typical fastener placement at endlaps and eave strut.

Typical fastener placement at ridge.

FOR MONARCH RIB® ONLY

IMPORTANT: Screw perpendicular to slanted surface as indicated

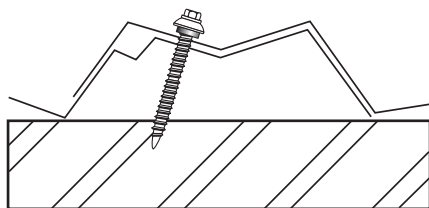

DRILLING / DRIVING TIPS FOR ALL OUR RIBS

IMPORTANT: Apply sufficient torque to seat the washer, **DO NOT OVER DRIVE THE FASTENER.**

IMPORTANT: Remove any metal filings created during fastener placement to prevent rust marks on the painted surface.

	WASHER	CORRECT	TOO LOOSE	TOO TIGHT
Weather-gard dome				

NOTE: 80 fasteners per square average quantity for roof. 60 Fasteners per square average quantity required for walls. You may require more or less depending on design requirement. Consult a qualified engineer or architect for specific requirements needed to meet local design codes, weather conditions or other related factors.

Note: Using a depth setting nosepiece is recommended for proper installation.

EXPOSED FASTENER INFORMATION

FASTENER PATTERN FOR SCREWS

5V CRIMP

Panel Coverage: 24"
Major Rib Spacing: 12"

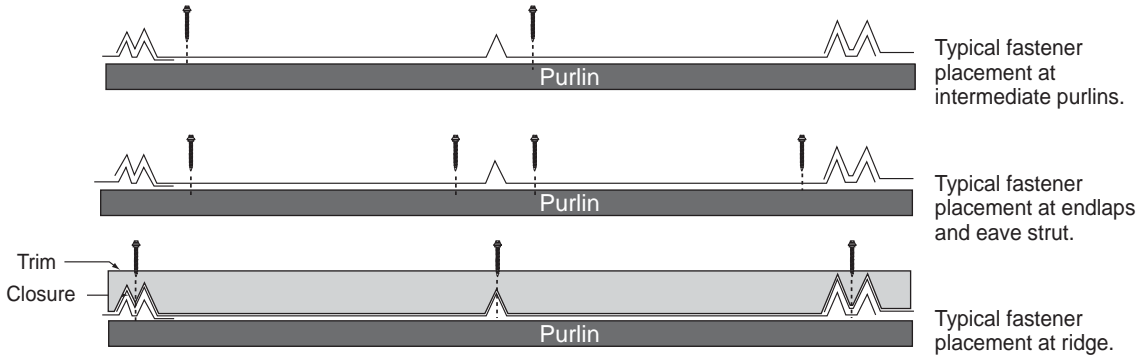

CORRUGATED

Panel Coverage: 24"

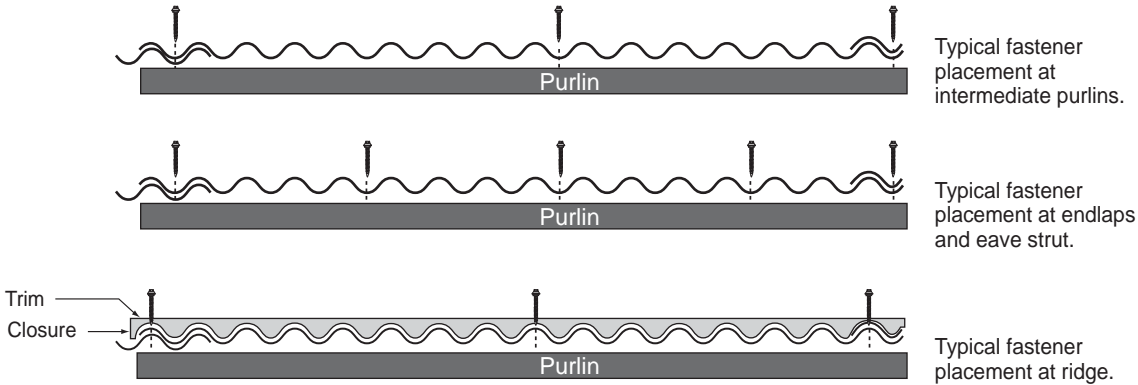

American Building Components recommends a #14 X 1", Type "A", hex head fastener with washer for all exposed fastener panels applied over a plywood or OSB substrate. The use of a #9 or #10 "wood grip" type fastener into plywood or OSB substrates is not recommended. This refers to exposed fastener panels installed over solid decks only. Open purlin construction, such as 2 X 4's on 24" center, should be fastened with #9 or #10 "wood grip" type fasteners.

Note: Using a depth setting nosepiece is recommended for proper installation.

TYPICAL DETAILS

Endlap Detail

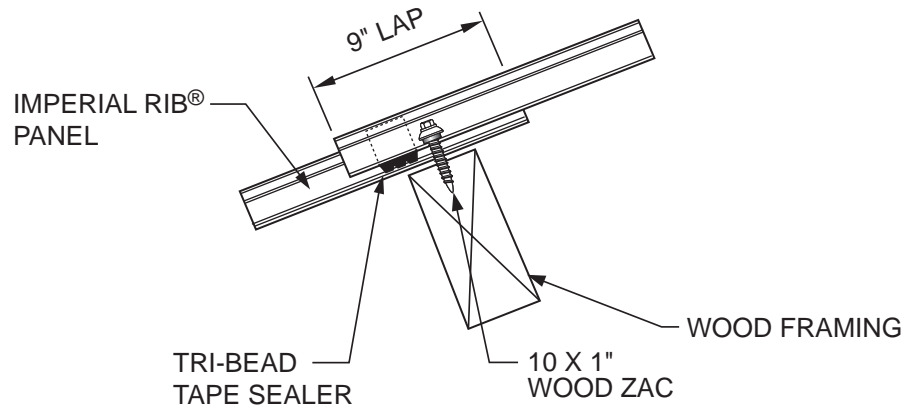

Cross Section of Endlap Over Wood

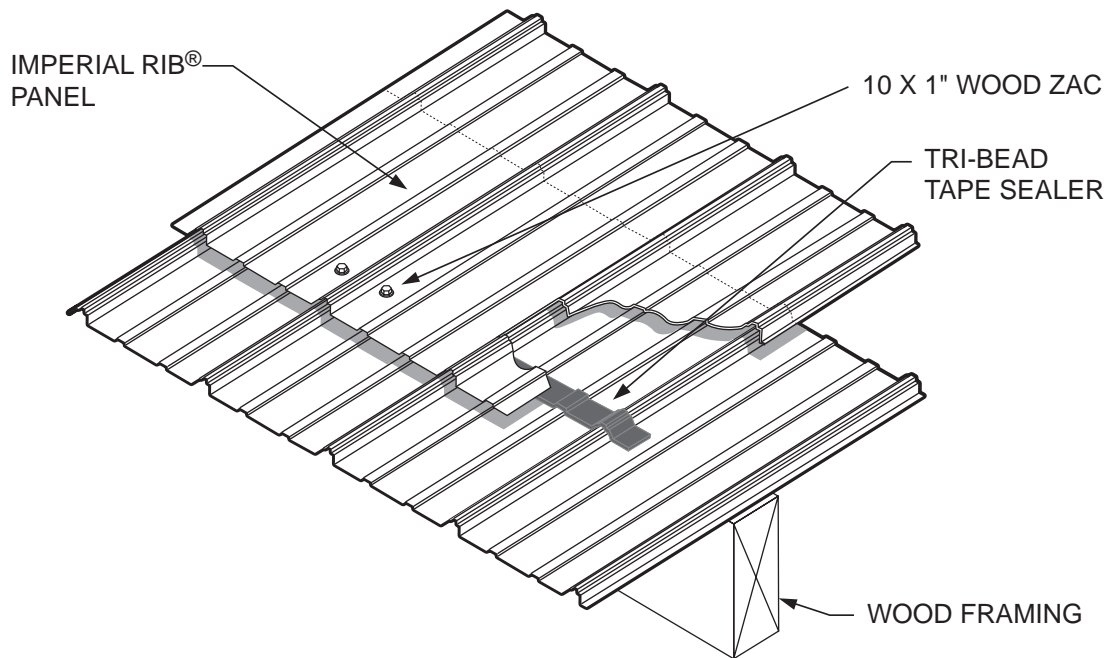

Isometric View of Endlap Over Wood

- NOTES:
1. Panel endlap is 9" under 4:12 pitch, over 4:12 6" is required.
 2. Install tri-bead tape sealer across width of bottom panel before installation of top panel. Top edge of tape sealer is 4 3/4" from up slope end of bottom panel.
 3. May be installed over purlins or a solid substrate.
 4. Reference fastener pattern page for endlap fastener placement.

TYPICAL DETAILS

Ridge Detail

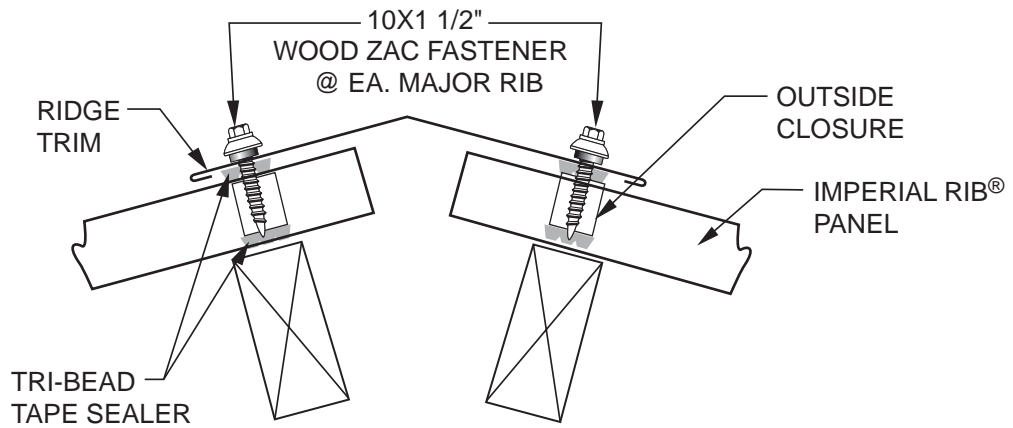

Cross Section of Ridge

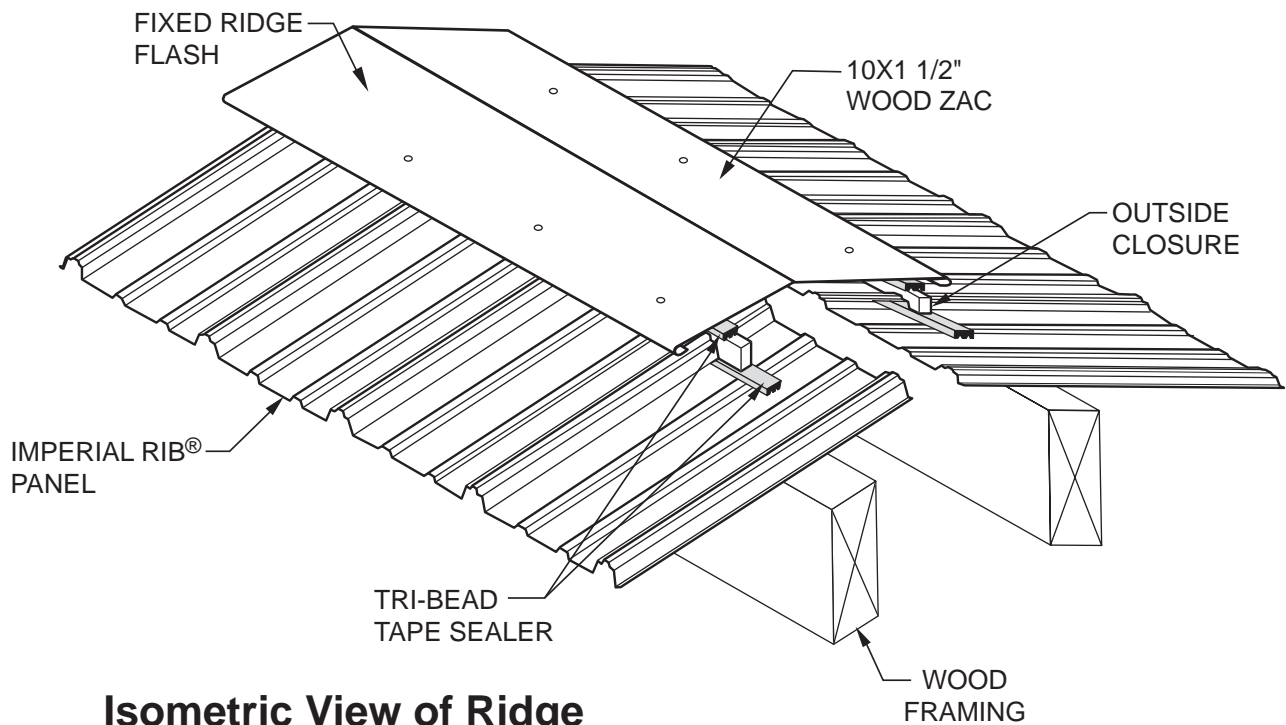

Isometric View of Ridge

- NOTES:**
1. Stop panels 2" from center line of ridge, or leave a gap of 1 3/4" between panels at the peak.
 2. Install tri-bead tape sealer across width of panels. Top edge of tape sealer is 1 3/4" from top edge of panel. Install outside closures on top of tri-bead tape sealer. Install additional run of tape sealer on top of outside closure.
 3. Attach ridge flash with 10X1 1/2" wood zac fasteners. Install fasteners at each major rib in the panel to avoid dimpling the ridge flash.
 4. Moisture Barrier required top solid substrate.

TYPICAL DETAILS

Valley Detail

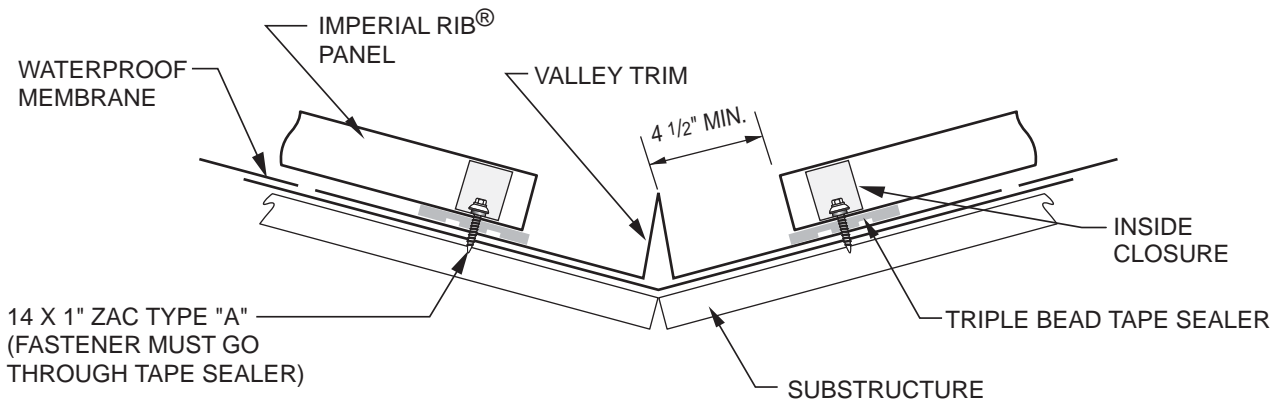

Cross Section of Valley Over Wood Deck

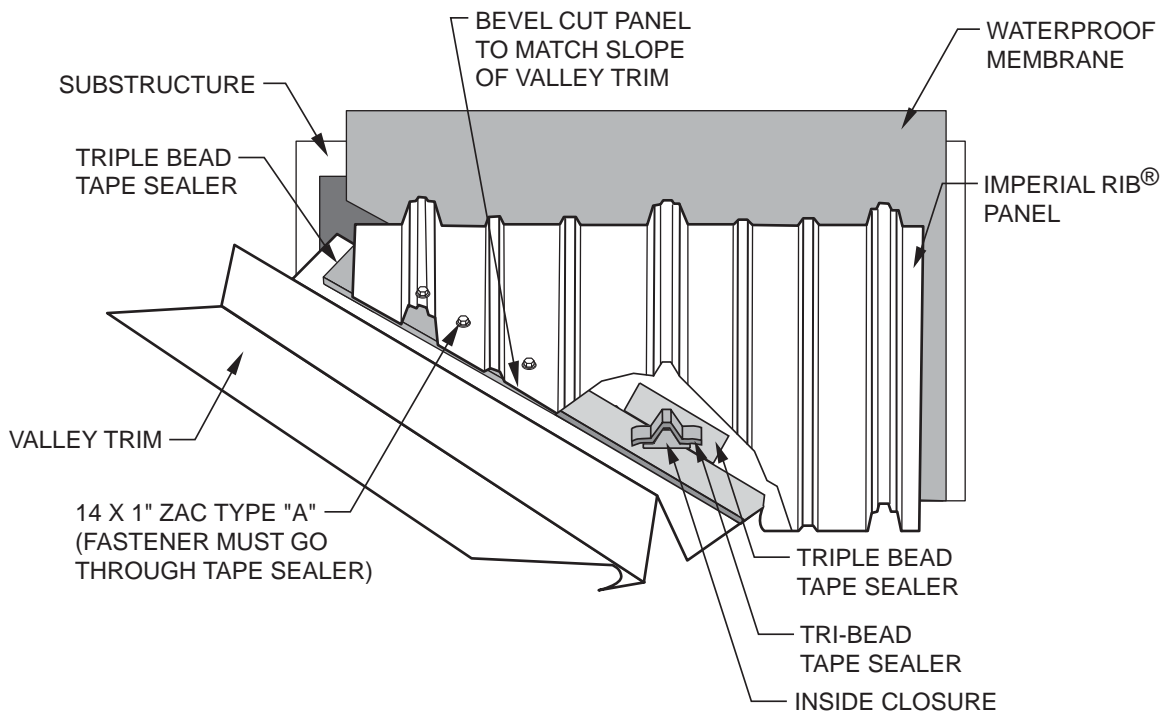

Isometric View of Valley

- NOTES:**
1. For valleys 30' or less in length, use standard valley trim. Valleys longer than 30' require extended valley trim.
 2. Use rubberized asphalt membrane as a waterproof membrane in the valley area, or other acceptable water proofing.
 3. Apply triple bead tape sealer to valley trim parallel to slope. Bottom edge of tape sealer is 4 1/2" from center of valley trim for standard valleys and 9" for extended valleys.
 4. Install high rib section of inside closure that has been field cut from standard 36" straight closure. Place the cut closure square with the rib of the panel. Install tri-bead tape sealer to top of inside closure prior to laying panel edge down on top of the cut closure. the triple bead tape with proper fastener sequence will seal the minor ribs of the panel that are between the major ribs.
 5. Bevel cut panel to match slope of valley trim.
 6. Fasten panel at valley with 14X1" wood zacs 4" O.C. maximum.

TYPICAL DETAILS

Hip Detail

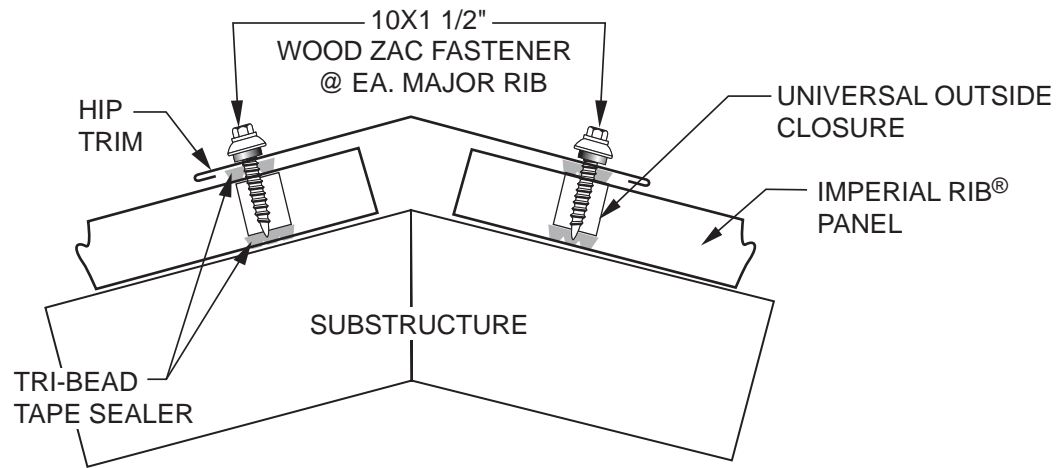

Cross Section of Hip

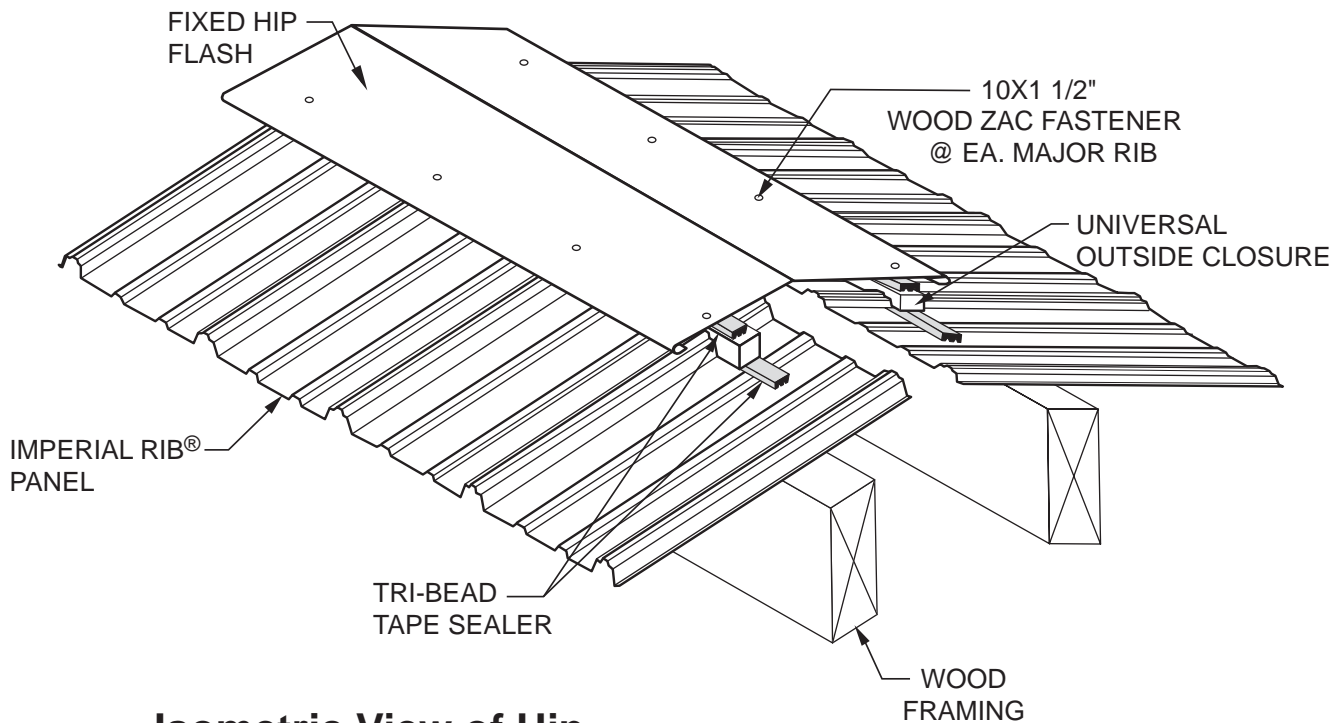

Isometric View of Hip

- NOTES:**
1. Bevel cut panels to match slope of hip and install
 2. Install tri-bead tape sealer across panels parallel to slope of hip. Top edge of tape sealer is 1 1/2" from center of hip.
 3. Notch bottom of universal closure at each "V" of the panels. Set bottom of universal closure on top of tape sealer.
 4. Install tri-bead tape sealer to top of universal closure and attach hip flash with 10 X 1 1/2" Wood Zac at each high rib of panel.

TYPICAL DETAILS

Rake Detail

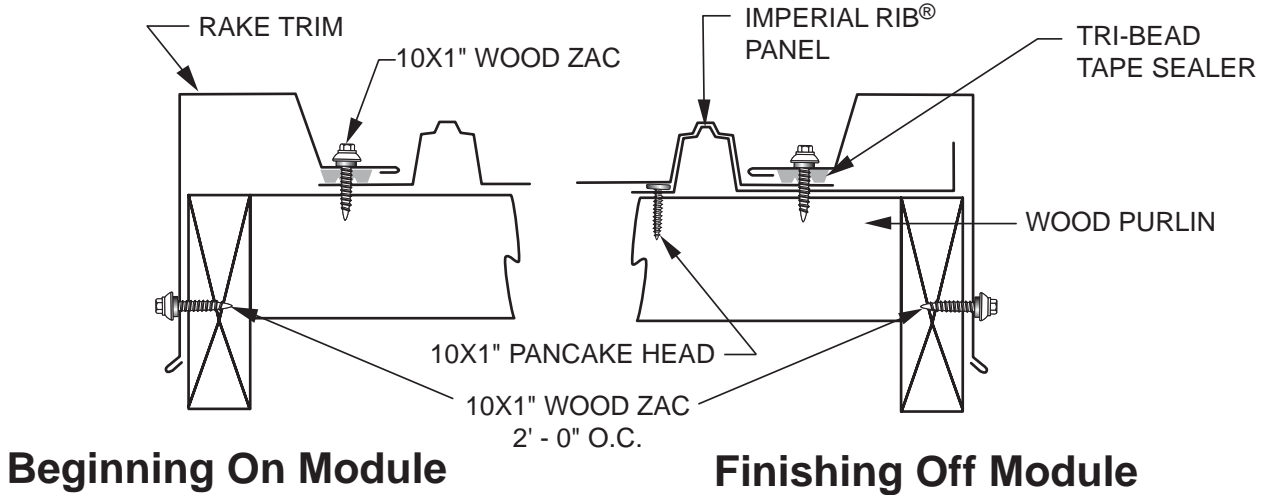

Beginning On Module

Finishing Off Module

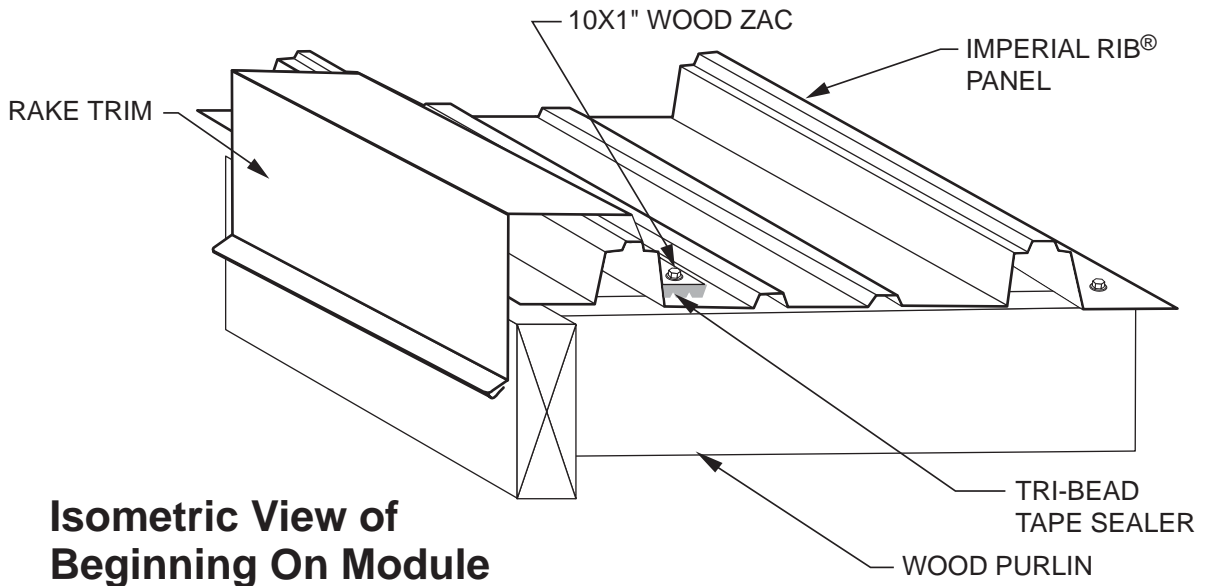

Isometric View of Beginning On Module

NOTES:

Rake Trim

1. Install rake trim to roof panels with 10 x 1" wood zacs 1' - 0" O.C. Fasteners must go through tri-bead tape sealer.
2. When finishing off module, field bend a 1/2" leg up on panel before installing rake trim.

Alternate Drip Trim

1. Fasten drip trim to roof deck with pancake head fasteners 2'-0" O.C.
2. Cut panel and bend a 1" open hem along length of panel.
3. Hook panel onto extending leg of drip trim and fasten panel to roof deck in normal manner.

TYPICAL DETAILS

Eave Detail

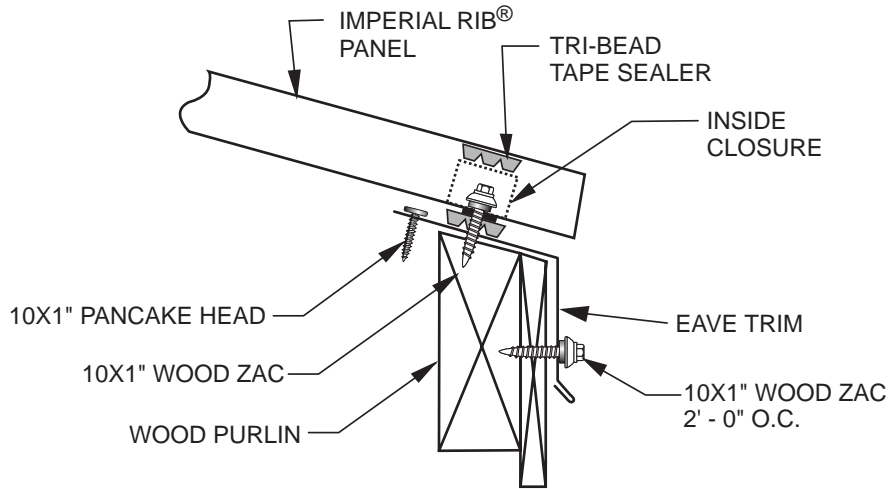

Cross Section of Eave Trim

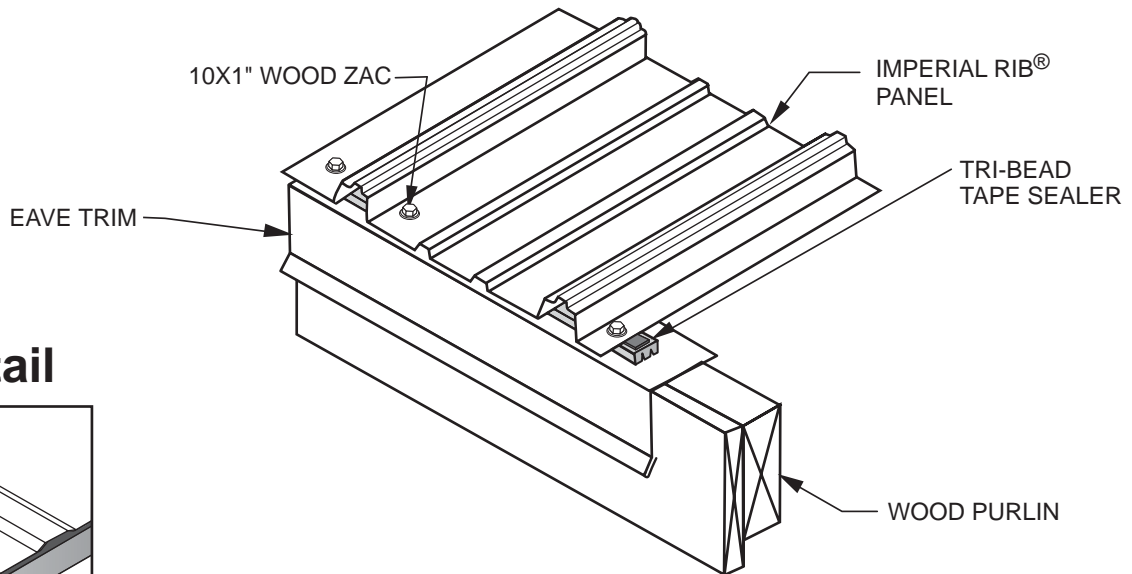

Panel End Detail

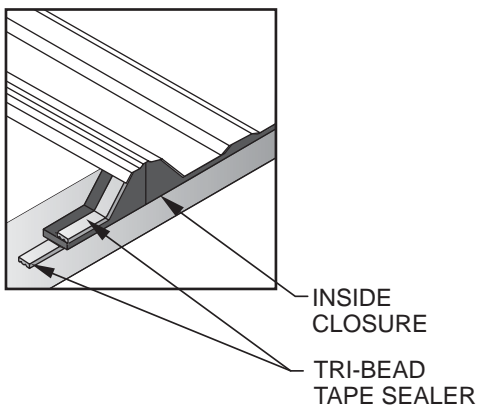

Isometric View of Eave Trim



- NOTES:**
1. Attach eave trim to roof deck with pancake head fasteners (2 fasteners per 10' section).
 2. Install tri-bead tape sealer along top leg of eave trim. Install inside closure on top of tri-bead tape sealer. Apply tri-bead tape sealer to top of outside closure.

TYPICAL DETAILS

Gutter Detail

Cross Section Eave with Gutter

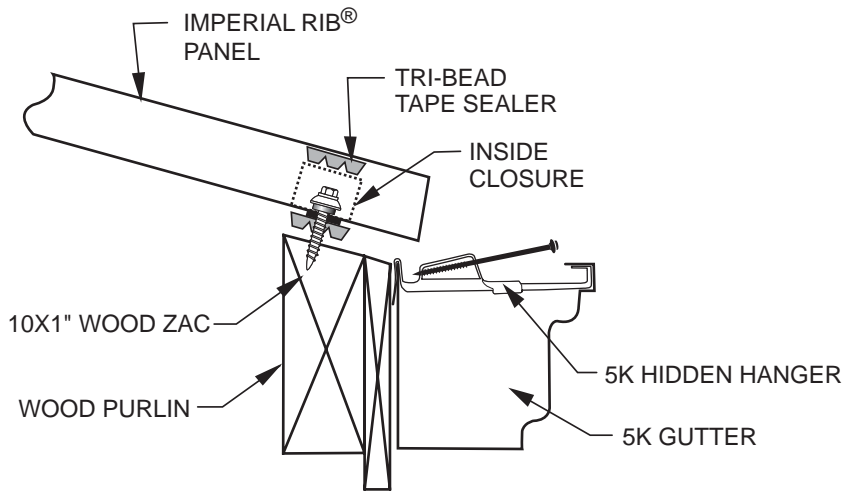

Panel End Detail

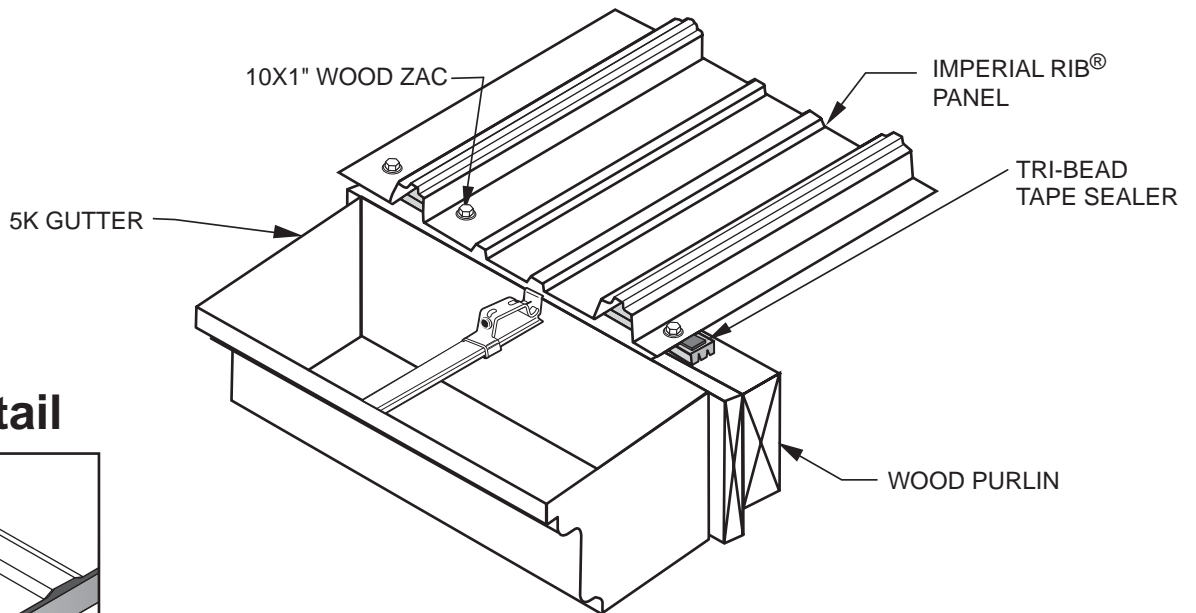
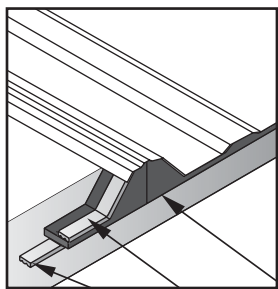

Isometric View of Eave with 5K Gutter

- NOTES:**
1. Install metal drip edge along eave of roof before installing roof panels.
 2. Drill 5/8" hole in front face of gutter 4' - 0" O.C. to receive gutter spikes.
 3. Slide back leg of gutter behind metal drip edge and drive spike and ferrule assembly through metal drip edge, back leg off gutter and into fascia board.
 4. In areas of extreme ice or snow build-up, consider eliminating the gutter and using eave trim instead.

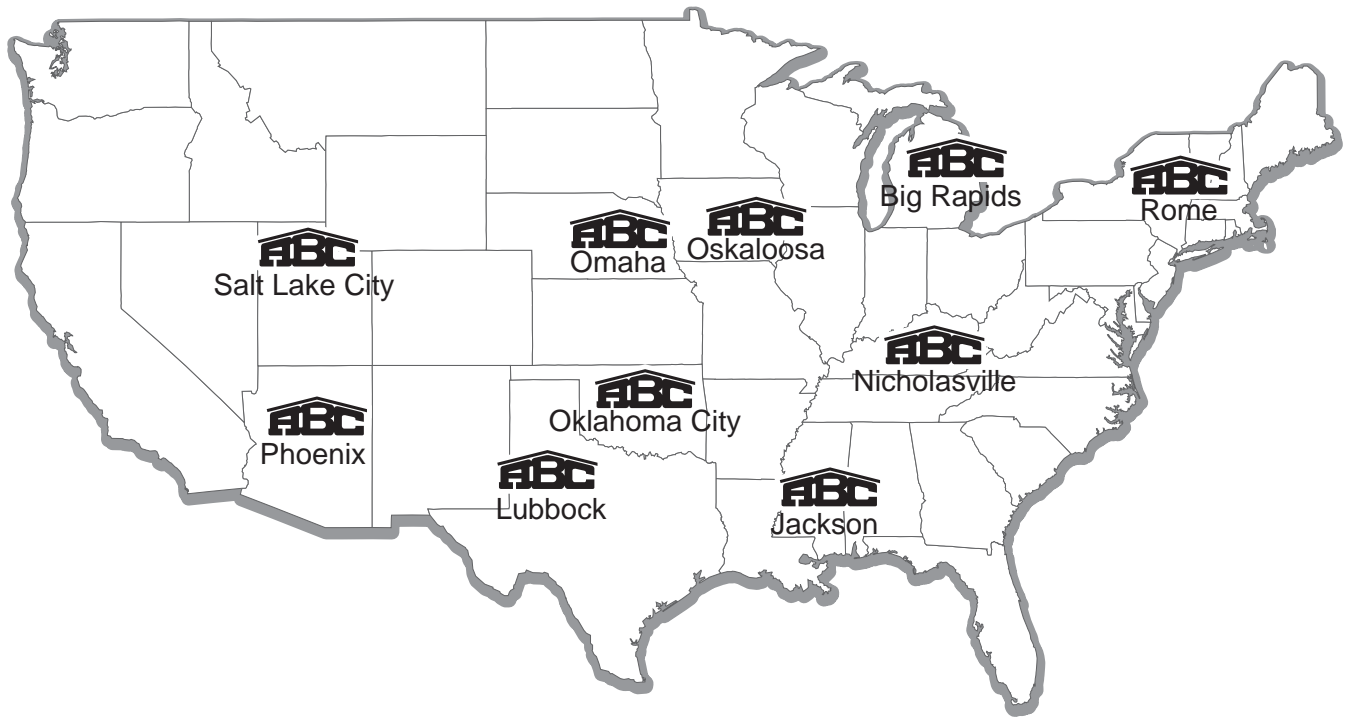

Contact American Building Components at
the plant located nearest you for
information on any of our fine products.
For the most current information see our website at
www.abcmetalroofing.com



BIG RAPIDS, MI
866-334-4222

JACKSON, MS
800-877-8709

LUBBOCK, TX
800-481-3035

NICHOLASVILLE, KY
800-877-8709

OKLAHOMA CITY, OK
800-228-2260

OMAHA, NE
800-228-2260

OSKALOOSA, IA
800-345-0044

PHOENIX, AZ
800-481-3035

ROME, NY
800-544-2651

SALT LAKE CITY, UT
800-481-3035

Rugged Rib[®], Regal Rib[®], Imperial Rib[®], Ameri-Drain[®], Monarch Rib[®], 7/8" Wide Rib[®], Perma Clad[®], SL-16[®], and Royal Lock[®] are registered trademarks of American Building Components. Galvalume[®] and Galvalume Plus[®] are registered trademarks of BIEC International.